

Datasheet **CRW- Family** wide input voltage range DC-DC converter

7 W Rugged Industry-, Mobile Rail-, Military and Avionics board mountable

Description

The CRW- DC/DC- converter fly-back family is built with planar filter and transformer offering exceptional performance. It is SMT though-hole mountable.

Application

It is designed for any rugged Industry-, Rail – Avionics- and Military application.

Electrical Specifications

Very wide input voltage ranges from 14.4 V_{dc} to 75 V_{dc} with 1 or 2 outputs 3 V_{dc} up to 48 V_{dc}

Ambient temperature -40 ... +85°C (convection cooling)

Isolation test in/out 1500...2500 V_{dc}, 1500 V_{ac}.



Ultimate unique family feature:

- uses exclusively ceramic capacitors
- no use of polarised capacitors at all
- stable over an extremely long service life

Features	Benefits	Page
Input		2
14.4 –168 V _{dc} (tba) extremely wide input voltage ranges	Ideal for rugged application 24 V _{dc} to 110 V _{dc} (tba) batteries	2
1.5 kW / 1 ms input transient protection	Fit for rail and other harsh environment	
Emissions below EN 55 022 level B	Exceeds international standards	3
Immunity acc. IEC/EN 61000-4-2, -3, -4, -5 and -6	Built to survive in harsh environment application	
Output		3
3.3V, 5V, 12V / 15V and 24 Vdc outputs	3.3 and 6 V _{dc} in preparation, 12 V / 15 V and 24 V _{dc} coming soon	
Voltage setting accuracy ± 0.5 %	Tight, accurate control	3
Temperature coefficient ± 0.02 %/K		
75% to 107% output adjustment (ref. to primary)	Easy adjustable, resistive or via ref. voltage	4
Ripple and noise (20 MHz BW limit)	25 mV _{pp} typ., extremely quiet for sensitive application	5
Line regulation	Tight, fast and accurate regulation	3
Load regulation		3, 4, 6
Output voltage protection	Increases overall system reliability	6
Infinite no load-, overload- and short circuit proof	Fully protected, inherent safe	3
Short circuit behaviour	Self recovery hiccup output power limitation	
General		
High efficient, typ. 84 %	No heat sink required, low cost of ownership	6
Supplementary isolation 1.5 kV	Robust isolation in harsh environment	4
Remote ON/OFF	Remote controllable, on – 10...0.8, off + 2...75 V _{dc}	4
Single and / or dual isolated outputs	Helps reduce service stock	3, 4
Switching frequency 400 kHz	Optimising filtering and load change deviation	4
Infinite no load-, overload- and short circuit proof	Fully protected, inherent safe	3
Mechanical		7
Dimensions: ≤ 8 mm low profile 2"x1", 48 x 23 mm	Ideal for low profile application	7
Industry footprint	Pin to pin replaceable to increase reliability	
SMT construction	Perfect reproducible reliability	
Integrated planar magnets	State of the art with many advantages over wire wound	8
Useful operation height 45'000 feet	Good for avionics application as well	
No electrolytic, no tantalum capacitors used	Stable over extremely long service life	1, 7
Open PCB (not potted)	Good convection cooling, no hot spots, easy cleaning	
RoHS compliant	Fit for an extreme wide field of applications	
Weight 14 gram	Good for airborne application as well	7
Environmental specification		8
Operating temperature -40 ... +85°C	Convection cooled for rugged and harsh environment	8
Storage temperature –55 ... +125 °C	For global storage	
Cooling: free air convection	Simple and easy to use	7
Reliability	High MTBF = long service life	8
Notes	For your convenience	

Datasheet **CRW- Family** wide input voltage range DC-DC converter

7 W Rugged Industry-, Mobile Rail-, Military and Avionics board mountable

Block diagram

The feedback loop is integrated in the primary side of the converter transformer.

No additional feedback transformer or opto-coupler for voltage feedback circuit

➔ higher reliability, lower cost of ownership.

Fig. 1 Fly-back converter block diagram

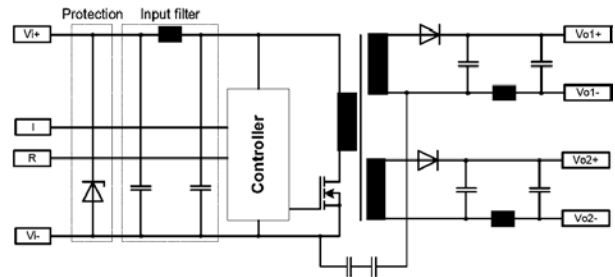

Input specification valid for input voltage, load and temperature ranges unless otherwise stated.

Parameter	Conditions/Description	Min.	Nom.	Max.	Unit
Maximum input voltage	Continuous			100	V _{dc}
Nominal input voltage	Wide input range (higher V _{in} tba)	16.8	40	75	V _{dc}
Input under voltage lockout					
Turn-on threshold	Self recovering, no latching		15		V _{dc}
Turn-off threshold			14		
Input voltage transient protection	during 1 ms		100		V
Peak power			1500		W
Peak current	I _p		11		A
Rise time	Resistive load		5		ms
	Capacitive load		12		
Inrush peak current	V _i = V _{inom}		3.7		A
Switching frequency			400		kHz

Input voltage protection: the converter has a powerful suppressor diode at the input. This is an excellence protection against transients and surges. Transients are often caused by inductive switching operations between +Vi and -Vi in excess of the absolute maximum ratings may cause performance degradation, adversely effect long-term reliability or can cause permanent damage to the converter. It acts at the same time as reserve polarity protection

External Components recommended meeting EN-50155 2 kV surge, criterion B

Component	Type	Value
Diode	suppressor diode	1.5KE39A or equivalent
Capacitor 1	wet Alum, Tantalum	68 μF, up to 200 V _{dc}
Inductor	Ring core	≥ 300 μH ≥ 1 Ampere
Capacitor 2	Multilayer ceramic	1 μF, up to 200 V _{dc}

Fig. 2 Schematic diagram external components

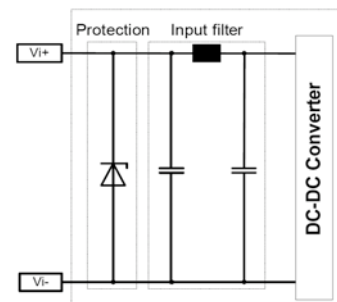

An internal input filter reduces the noise level in addition and keeps the converter more stable.

Datasheet **CRW- Family** wide input voltage range DC-DC converter

7 W Rugged Industry-, Mobile Rail-, Military and Avionics board mountable

EMC / RFI and ESD, transients and surges

Parameter	Description	Criterion
Electrostatic discharge	IEC/EN 61000-4-2, level 4 (contact/air)	8/15 kV, Performance criterion B
Electromagnetic field	IEC/EN 61000-4-3, level 3	10 V/m, Performance criterion B
Electrical fast transients/burst	IEC/EN 61000-4-4, level 3 (+/-i)	4 kV, Performance criterion B
Surge	IEC/EN 61000-4-5, level 3 (+/-i) external components see Fig. 1	2 kV, Performance criterion B
RF conducted immunity	IEC/EN 61000-4-6	10 Vac, AM 80 %, 1 kHz Performance criterion A
Conducted emissions	CISPR 22/EN 55022/EN 61204	Class B
Radiated emissions	CISPR 22/EN 55022/EN 61204	Class B

Emissions

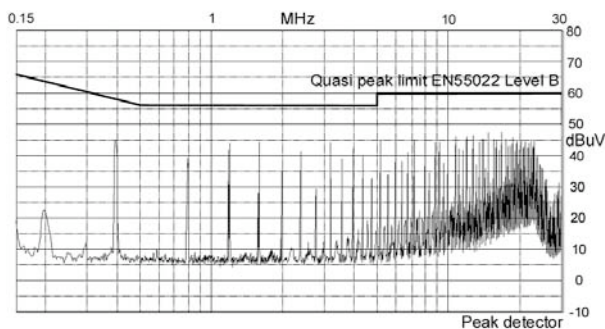

Fig. 3 Conducted Peak measurement CISPR 11 / EN 55011 and CISPR 22 / EN 55022 at the input, full load (typical).
Limit: EN-55022 level B (quasi peak)
(with external capacitor 1 μ F at the input)

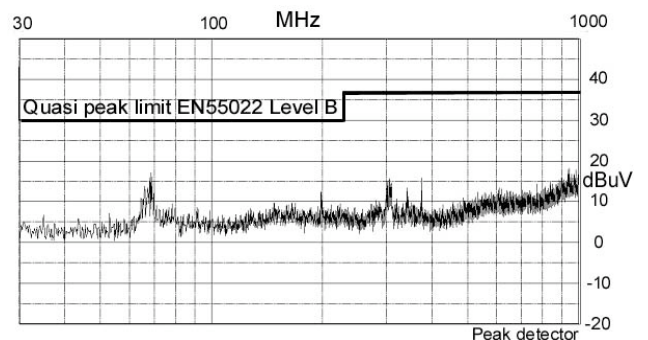

Fig. 4 Radio Frequency Interference measurement at U_{inom} , I_{onom} with antenna distance of 10 m (typical).
Limit: EN-55022 level B (quasi peak)
(with external capacitor 1 μ F at the input)

Output Specification for 5 V_{dc} single and dual outputs. Other output voltages, 3.3, 6, 12, 15 and 24 V_{dc} tba.

Parameter	Condition/Description	Min	Nom	Max	Unit
Nominal output voltage	50 ... 100 % load				
CRW5.0-6Er00 (single output)	50 ... 100 % load output 1		5		V _{dc}
CRW5.0/5.0-6Er00 (two out)	50 ... 100 % load output 2				
Line regulation			± 0.5	± 1	% V _{out}
Load regulation	20 ... 100 % load		± 2.5	± 5	
Nominal output current	Output 1	1.4			A
CRW5.0-6Er00 (single output)	Output 1	0.7			
CRW5.0/5.0-6Er00 (two out)	Output 2	0.7			
Ripple	See Fig. 3 - 6			25	
Nominal output power					W
CRW5.0-6Er00		0	7		
CRW5.0/5.0-6Er00					
Output voltage noise	$I_o = I_o \text{ nom}$		20	40	mV _{pp}
Short circuit behaviour	Self recovery hiccup mode output power limitation			infinite	
Admissible capacitive load					μ F
CRW5.0-6Er00 (single output)	Output 1	2000			
CRW5.0/5.0-6Er00 (two out)	Output 1 and 2 wired together	2000			

Datasheet CRW- Family wide input voltage range DC-DC converter

7 W Rugged Industry-, Mobile Rail-, Military and Avionics board mountable

Output Specification for 5 Vdc single and dual outputs. Other output voltages, 3.3, 6, 12, 15 and 24 VDC tba.

Parameter	Condition/Description	Min	Nom	Max	Unit
Admissible capacitive load CRW5.0-6E00 (single output) CRW5.0/5.0-6E00 (two out)	Output 1 Output 1 and 2 wired together	2000 2000			μF
Input under-voltage Lockout Turn-on threshold Turn-off threshold	Non latching		15 14		Vdc
Input Voltage Transient Peak Power Peak Current	100V, 1 ms		1500 11		W A
Supplementary isolation 1.5 kV	EN-50155		1500		V _{ac} 1 min.
Rise time	Resistive load (see page 4, Fig. 19 - 21) Resistive and capacitive load (see fig. 20-22)		0.8 4		ms ms
Dynamic Response time	Resistive load step (20-100%, I _{onom}) R and C load step (20-100%, I _{onom}) C= 2 x 1000 μF (see fig. 23-25)		80		μs
Inrush peak current	V _i = V _{inom}		3.7		A
Remote ON/OFF	ON – 10 ... + 0.8 V _{dc} OFF + 2... + 75 V _{dc}	- 10		+ 75	V _{dc}
Switching frequency	under any line- and load condition		400		kHz

Start-up behaviour:

The dynamic load response behaviour is measured with both setups (all typical values CRW5.0-6E00):

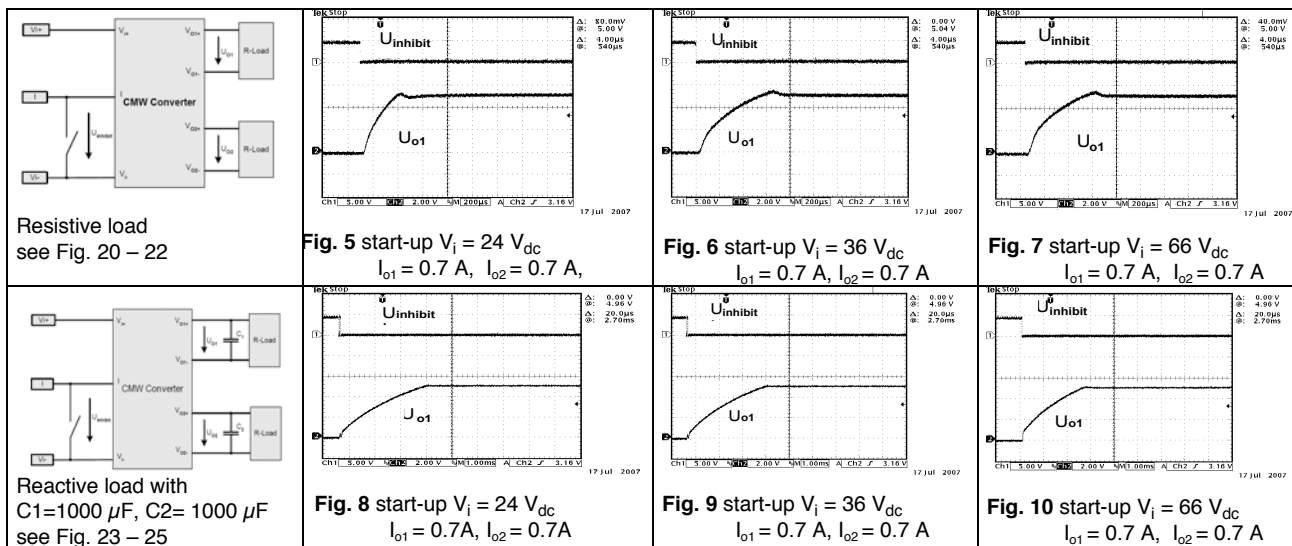

Datasheet **CRW- Family** wide input voltage range DC-DC converter

7 W Rugged Industry-, Mobile Rail-, Military and Avionics board mountable

Output Voltage Adjustment (R pin)

The output voltage can be adjusted on the primary side up by + 7.5% or down by - 25%. Increasing the output voltage, a resistor can be connected between R and V_{i-} . Decreasing the output voltage, an external voltage must be connected between R and V_{i-} .

V_o [% of V_{onom}]	V_{extern} [% of V_{onom}]	3.3 V_{dc} out	5 V_{dc} out	5.1 V_{dc} out	6 V_{dc} out	12/15 V_{dc} out	24 V_{dc} out
106-108 (typ. 107)	0.93	3.53	5.33	5.46	6.42	16.05	25.68
105	0.95	3.47	5.25	5.36	6.30	15,75	25,20
104	1.3	3.43	5.20	5.30	6.24	15.60	24.96
103	1.4	3.40	5.15	5.25	6.18	15.45	24.72
102	1.6	3.36	5.10	5.20	6.12	15.30	24.48
101	2.15	3.33	5.05	5.15	6.06	15.15	24.24
100	2.5	3.30	5.00	5.10	6.00	15.00	24.00
95	4.0	3.14	4.75	4.85	5.7	14.25	22.80
90	5.7	2.97	4.50	4.59	5.40	13.50	21.60
85	10.2	2.81	4.25	4.34	5.1	12.75	20.40
75	13.8	2.48	3.75	3.83	4.50	11.25	18.00
Single output mA	Dual Output mA /out	2100 / 1100	1400 / 700	1400 / 700	1200 / 600	500 / 250	300 / 150

Table 1 values are typical @ 60% load

Load Regulation

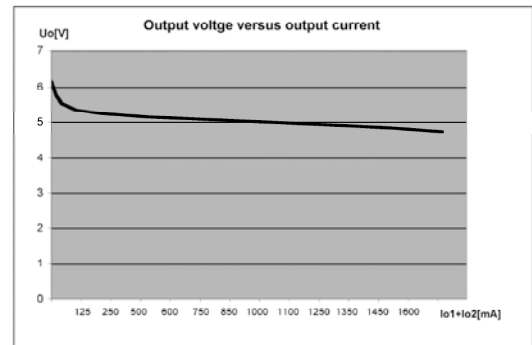
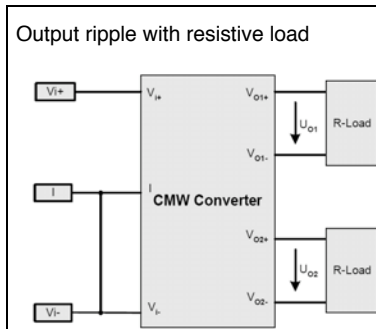

Fig. 11 Output voltage versus output current

Ripple



$I_{out1} = 0.7A$ $I_{out2} = 0.7A$, BW 20 MHz

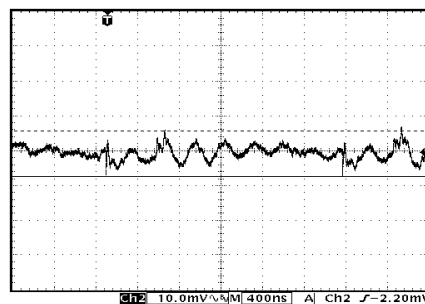

Fig. 12 $U_{in} = 24 V_{dc}$, Ripple = 13 mV

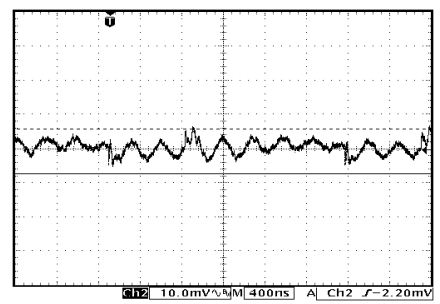
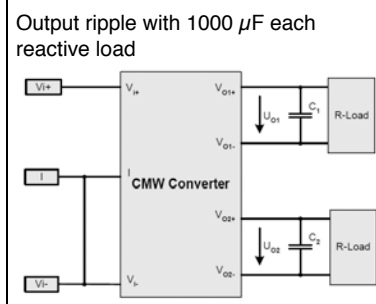

Fig. 13 $U_{in} = 66 V_{dc}$, Ripple = 16 mV



$I_{out1} = 0.7A$ $I_{out2} = 0.7A$, BW 20 MHz
 $C1 = 1000 \mu F$, $C2 = 1000 \mu F$

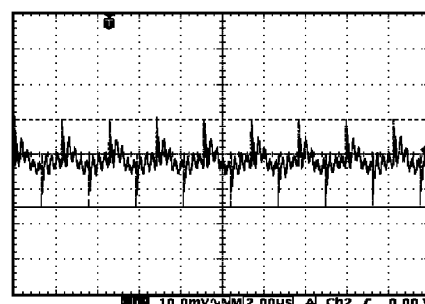

Fig. 14 $U_{in} = 24 V_{dc}$, Ripple = 25 mV

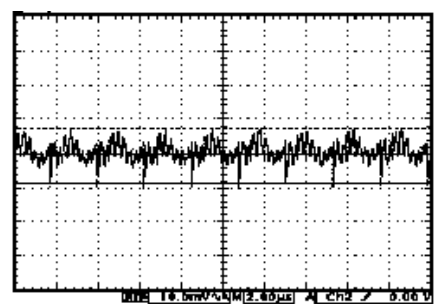

Fig. 15 $U_{in} = 66 V_{dc}$, Ripple = 13 mV

Datasheet **CRW- Family** wide input voltage range DC-DC converter

7 W Rugged Industry-, Mobile Rail-, Military and Avionics board mountable

Output Over- voltage protection

The outputs of the converter are protected against internal and external over voltage by zener diodes. Note: The zener diodes will not withstand externally applied over voltages.

Efficiency

The following figures show the efficiency and power losses of the converter (Typical values CRW5.0-6Er00)

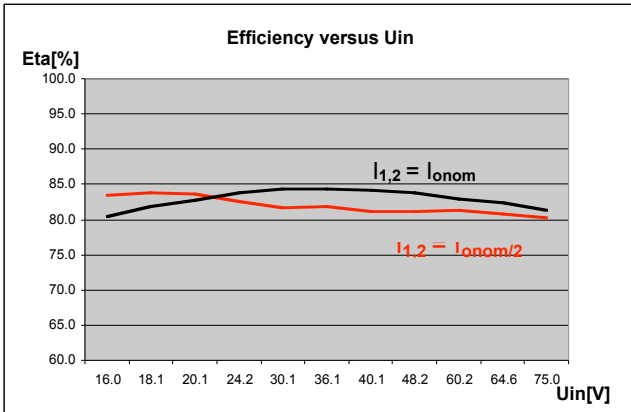

Fig. 16 Efficiency CRW5.0-6Er00 (typical values)

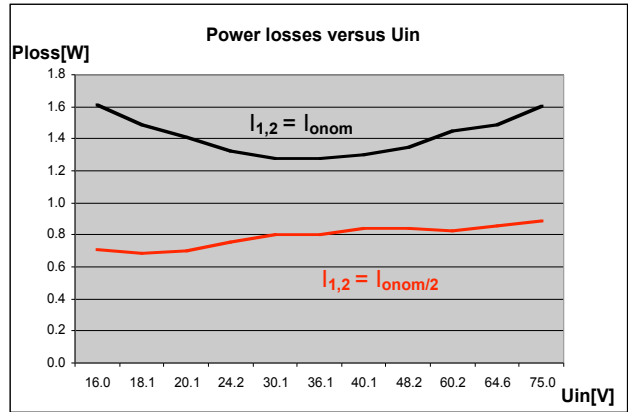
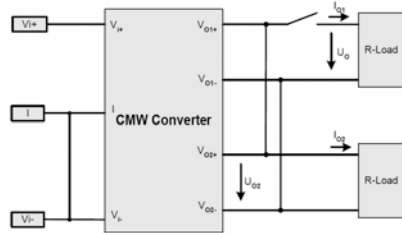

Fig. 17 Power loss CRW5.0-6Er00 (typical values)

Dynamic Response Fig. 18-21

The dynamic load response behaviour is measured with this setup:



Upper lines: V_{out} (DC triggering)
Lower lines: ΔV_{out} (AC triggering)

All measurements with CRW5.0-6Er00, typical values

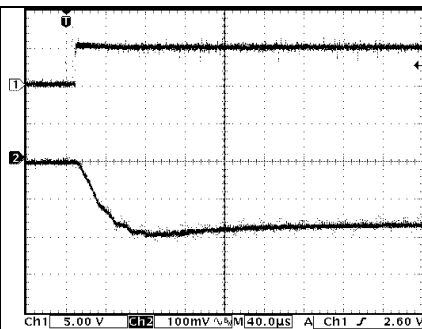

Fig. 18 positive load step
50 – 100%, $\Delta I = 0.7A$

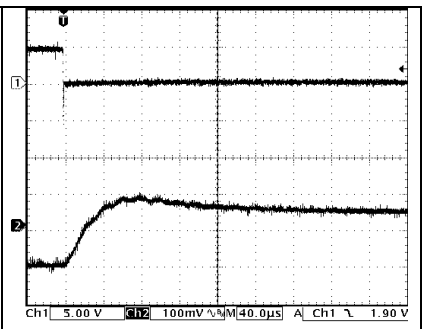

Fig. 19 negative load step
100 – 50%, $\Delta I = 0.7A$

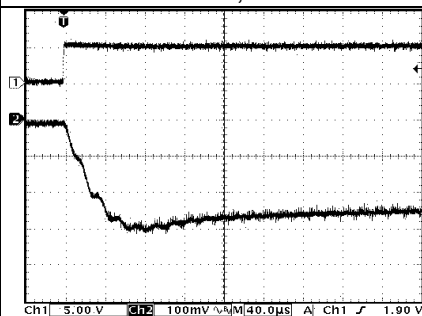

Fig. 20 positive load step
20 – 100%, $\Delta I = 1.1A$

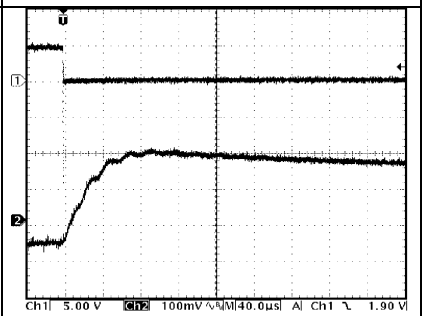

Fig. 21 negative load step
100 – 20%, $\Delta I = 1.1A$

Datasheet **CRW- Family** wide input voltage range **DC-DC** converter

7 W Rugged Industry-, Mobile Rail-, Military and Avionics board mountable

Thermal behaviour

The CRW family show excellent thermal behaviour. It is designed for convection cooling. Free air convection is around 10 to 20 LFM. Forced air-cooling is normally not required. Please observe the operating temperature in the final system. The converter is laid out to distribute heat (low power-losses) evenly over the entire printed circuit board very well. $\Delta t \leq 25^\circ\text{C}$

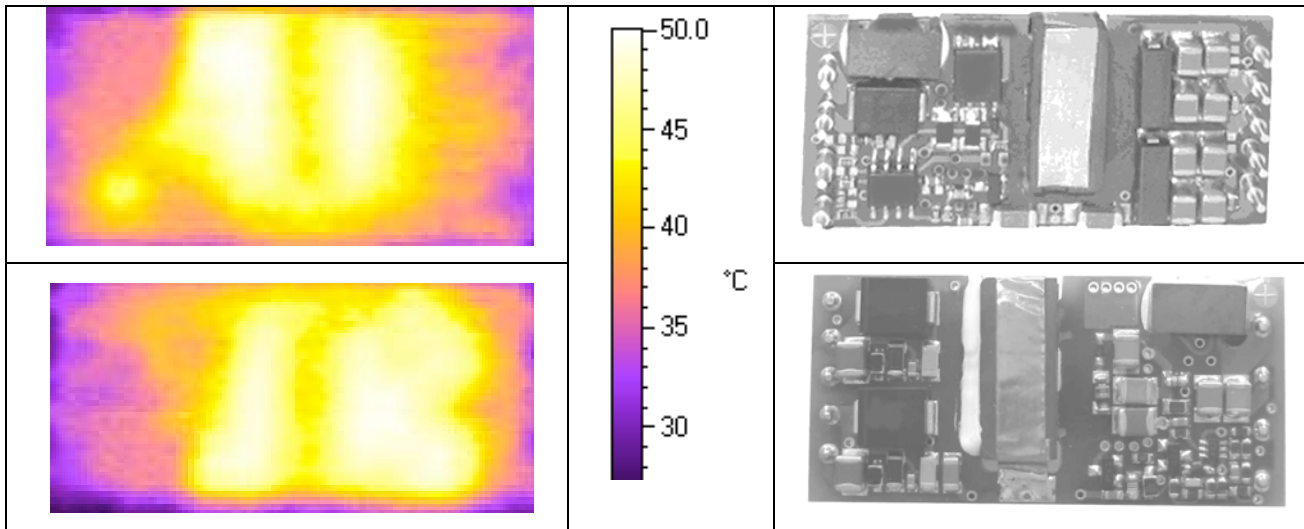

Fig. 22-24 thermal behaviour CRW5.0-6Er00 ($I_{o1}, I_{o2} = 0.7\text{A}$ (100%), $T_A = 25^\circ\text{C}$, $T_{PCBmax} = 50^\circ\text{C}$, convection cooling)

Mechanical Data

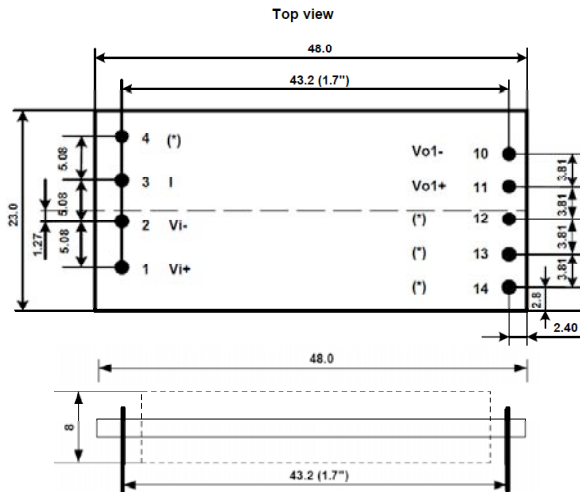

Fig. 27 top and side view, dimensions are in mm

Pin	Single Output	Two Outputs
1	+ Vin	+ Vin
2	- Vin	- Vin
3	shut down	shut down
4	R trim, opt. empty	R trim, opt. empty
10	- Vout 1	- Vout 1
11	+ Vout 1	+ Vout 1
12	- Vout 2	- Vout 1
13	+ Vout 2	+ Vout 2
14	n. c. pin available	n. c. pin available

(* optional, custom marking suffix "C")

Fig. 28 Single and two output variants

Weight: 14 gram

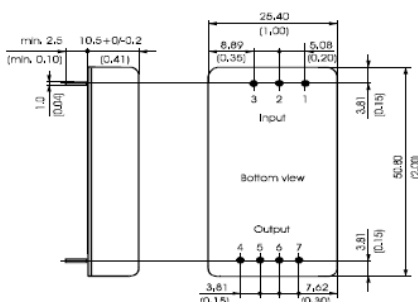

Pin	Function
1	+ Vin
2	- Vin
3	i
4	- Vout 1
5	+ Vout 1
6	- Vout 2
7	+ Vout 2

Competitor A

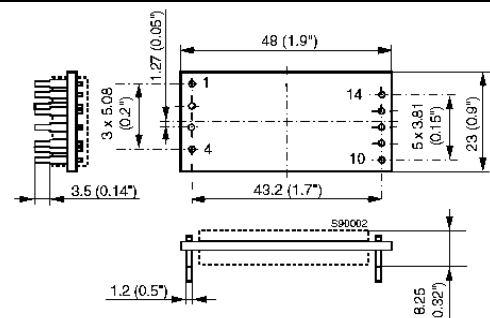

Competitor B

Datasheet **CRW- Family** wide input voltage range DC-DC converter

7 W Rugged Industry-, Mobile Rail-, Military and Avionics board mountable

Environmental specification, Shock and Vibration

Parameter	Conditions/description	Min	Nom	Max	Unit
Shock	IEC/EN 60068-2-27, 11 ms			40	g_{pk}
Sinusoidal vibration	IEC/EN 60068-2-64 2-8 Hz 8-200 Hz 200-500 Hz		7.5 2 4		mm g_{pk} g_{pk}
Random vibration	10-2000 Hz		6.15		g_{rms}

Other environmental specification:

Parameter	Conditions/description	Min	Nom	Max	Unit
Operating temperature		-40		+85	°C
Storage temperature		-55		+125	
Operating altitude	Operating			40 k	ASL ft.
Relative humidity, non- condensing	Operating	10		98	% RH
	Storage	5		95	% RH
Temperature coefficient	after 15 min warm-up time			0.02	%/K

Reliability data

MTBF	MilHdBk 217 Notices F and G	> 1'000	kh
MTBF	Calculated per Bellcore (SR-332, Issue 1):GB 40°C	> 1'500	kh

Marking

A label on the converter identifies type- and revision number. A comprehensive type key is on our home page.

Optional: Bar code 39 or 128 B, length 17 mm:



Type key

C = 7 Watt; R = nominal 24, 36 and 48 V_{dc} ; W = wide input voltage range;
5.0 = $V_{out 1}$; / = galvanic isolation between dual outputs, second 5.0 = $V_{out 2}$
E -25 °C...+85 °C operating temperature range; rxx = revision Nr.

Please visit our website, www.absopulse.ch EMP²ower, comprehensive type key



Notes
